

CALCIUM FLAT PLATE

B A T T E R I E S



Description

The EnerSys DXC is a durable multi-cell wrapped calcium flat plate battery. The DXC unit is optimized for long cycle life and high rate performance. It features the Yuasa time tested Slide-Lock™ post seal design and is most suited for UPS applications. This battery is rated at 100% capacity at initial discharge.

Features

Safe

- Cover made from Flame Retardant materials (UL94-V0/L.O.I.28%). Container made from Flame Retardant polycarbonate (UL94-V0/L.O.I.28%) optional.

Application

- UPS
- Switchgear

Economical

- Multi-cell construction requires fewer units, resulting in lower installation costs.

Performance

- All battery systems rated at 100% capacity at initial discharge.
- Expanded capacity - .594 kW to 5.089 kW per cell to 1.67 VPC at the 15 minute rate.
- Energy - optimized for high performance, short duration rates.
- High conductivity/high integrity - lead plated copper terminal posts.
- Footprint - space efficient design reduces footprint requirements.

Durable

- Cycling - Wrapped positive plate for long cycle life.
- 20 year life expectancy in float service at 77°F ambient temperature.
- Long life Slide-Lock™ post seal design.

MODEL

EXIDE

DXC

0.594kW-5.089kW

APPLICATIONS:

**UPS
SWITCHGEAR**

Specifications

PLATE THICKNESS:

- POSITIVE: .200 inches (5.1mm)
- NEGATIVE: .130 inches (3.6 mm)

PLATE SUSPENSION TYPE:

- POSITIVE: Bridge hung
- NEGATIVE: Bottom supported

CONTAINER:

- Styrene Acrylonitrile Copolymer
- Container made from Flame Retardant polycarbonate (UL94-V0/L.O.I.28%) optional.

COVER: Made from Flame Retardant PVC (UL94-V0/L.O.I.28%)

SEPARATORS: Microporous plastic

BOLT CONNECTORS:

- Stainless Steel, Standard English Measure, Hex-Head

INTERUNIT CONNECTORS:

- Lead-Plated Copper

ELECTROLYTE OVER PLATES:

- 2.88 inches (73.1mm)

VENT TYPE:

- Flame Arrestor, Fused Alumina

FLOAT VOLTAGE SETTINGS:

- ACCEPTABLE MIN/MAX: 2.17/2.26 VPC
- RECOMMENDED: 2.25 VPC for standard gravity (1.215 S.G.)

SEDIMENT SPACE:

- 1.04 inches (26.4 mm)

POSTS:

- Lead-plated copper insert
- DX-5 to DX-25 - one positive post and one negative post per cell.
- DX-27 to DX-35 - two positive posts and two negative posts per cell.

POST SEAL TYPE:

- Slide-Lock™

SPECIFIC GRAVITY:

- 1.215 standard(1.250 available upon request)

AVERAGE CELL PERFORMANCE DATA* (Discharge Rates in Amperes)**

TYPE	8 HR	7 HR	6 HR	5 HR	4 HR	3.5 HR	3 HR	2.5 HR	2 HR	1.5 HR	60 MIN	30 MIN	15 MIN	5 MIN	1 MIN ¹	1 MIN ¹ to 1.50 VPC
1.250 SPECIFIC GRAVITY TO 1.75 END VOLTS PER CELL																
DXC-5B	29.4	33.9	37.8	43.1	50.7	55.5	61.0	73.4	80.4	100.6	139.0	223.5	324.7	470.0	521.7	710.7
DXC-7B	42.3	47.1	54.2	61.2	73.7	80.4	87.1	106.7	117.3	146.7	204.6	333.7	481.8	698.5	778.5	1056.0
DXC-9B	55.2	61.2	70.7	79.4	94.7	101.4	110.4	138.0	151.5	190.9	268.2	440.1	634.9	922.8	1034.3	1392.9
DXC-11B	74.5	86.6	98.7	111.0	133.0	144.5	166.5	189.9	211.6	265.2	363.2	542.5	787.9	1021.9	1164.2	2039.1
DXC-13B	86.4	99.8	112.3	129.2	154.1	170.3	194.6	223.2	251.3	315.1	427.8	645.8	935.8	1226.8	1391.3	2441.5
DXC-15B	97.5	110.2	125.8	143.6	173.2	191.4	220.7	253.6	289.2	364.0	490.5	753.1	1078.5	1430.5	1616.3	2841.7
DXC-17B	106.7	119.6	136.5	159.8	192.4	213.4	245.9	282.9	326.2	411.0	553.1	853.6	1218.1	1635.3	1839.3	3240.9
DXC-19B	109.4	125.2	145.2	167.5	198.1	217.2	248.8	287.8	330.8	417.6	583.5	921.5	1296.6	1795.9	2029.6	3435.2
DXC-21B	121.4	139.4	162.6	185.7	219.2	241.2	276.8	319.2	367.8	464.6	712.7	1061.3	1503.4	2103.2	2374.4	3974.8
DXC-23B	134.3	153.5	178.1	203.8	241.2	265.1	304.0	351.5	403.8	510.7	770.5	1156.8	1636.8	2283.2	2489.0	4327.5
DXC-25B	146.2	167.6	194.6	223.0	263.2	290.0	332.0	383.8	440.7	557.7	825.3	1250.3	1768.1	2465.4	2698.7	4676.0
DXC-27B	183.0	207.2	241.0	274.7	329.2	358.9	395.9	471.9	525.8	664.9	905.6	1384.2	1953.2	2723.0	2998.4	5170.2
DXC-29B	190.4	215.6	251.7	287.1	342.6	375.1	418.2	492.4	551.6	699.7	958.4	1475.8	2081.4	2897.7	3211.2	5512.3
DXC-31B	195.0	224.1	261.4	298.6	355.0	386.6	420.1	513.0	572.0	731.7	1007.4	1566.3	2207.6	3066.9	3420.9	5847.1
DXC-33B	202.3	230.7	268.1	308.2	364.6	400.0	427.9	528.7	591.4	761.8	1055.4	1654.9	2329.6	3232.9	3627.6	6170.2
DXC-35B	206.9	237.3	275.9	315.8	373.2	408.6	435.6	543.3	609.8	789.1	1100.4	1741.6	2449.5	3393.5	3834.2	6490.2
1.215 SPECIFIC GRAVITY TO 1.75 END VOLTS PER CELL																
DXC-5	26.8	30.8	34.3	39.2	46	50	55	67	73	91	126	203	295	427	474	646
DXC-7	38.5	42.8	49.3	55.7	67	73	79	97	107	133	186	303	438	635	708	960
DXC-9	50.2	55.6	64.2	72.2	86	92	100	125	138	174	244	400	577	839	904	1266
DXC-11	67.7	78.8	89.8	100.9	121	131	151	173	192	241	330	493	716	929	1058	1854
DXC-13	78.6	90.7	102.1	117.5	140	155	177	203	228	286	389	587	851	1115	1265	2220
DXC-15	88.6	100.2	114.4	130.5	157	174	201	231	263	331	446	685	980	1300	1469	2583
DXC-17	97.0	108.7	124.1	145.3	175	194	224	257	297	374	503	776	1107	1487	1672	2946
DXC-19	99.5	113.8	132.0	152.3	180	197	226	262	301	380	530	838	1179	1633	1845	3123
DXC-21	110.4	126.7	147.8	168.8	199	219	252	290	334	422	648	965	1367	1912	2159	3613
DXC-23	122.1	139.5	161.9	185.3	219	241	276	320	367	464	700	1052	1488	2076	2263	3934
DXC-25	132.9	152.4	176.9	202.7	239	264	302	349	401	507	750	1137	1607	2241	2453	4251
DXC-27	166.4	188.3	219.1	249.7	299	326	360	429	478	604	823	1258	1776	2475	2726	4700
DXC-29	173.1	196.0	228.8	261.0	311	341	380	448	501	636	871	1342	1892	2634	2919	5011
DXC-31	177.2	203.7	237.6	271.4	323	351	382	466	520	665	916	1424	2007	2788	3110	5316
DXC-33	183.9	209.7	243.8	280.1	331	364	389	481	538	693	959	1504	2118	2939	3298	5609
DXC-35	188.1	215.7	250.8	287.1	339	371	396	494	554	717	1000	1583	2227	3085	3486	5900

*Ampere values listed represent 100% of the initial capacity.

**At 77°F (25°C) includes intercell connector drop.

¹One minute rates to 1.50 and 1.75 VPC should only be used for short circuit calculations and not as performance data.

All data subject to change without notice.

Average Cell Performance Data* Discharge Rates in KW Per Cell**

TYPE	5 MIN	10 MIN	15 MIN	20 MIN	25 MIN	30 MIN	45 MIN	60 MIN	90 MIN	120 MIN	180 MIN
1.250 SPECIFIC GRAVITY TO 1.75 END VOLTS PER CELL											
DXC-5B	0.832	0.697	0.597	0.523	0.462	0.415	0.326	0.255	0.186	0.156	0.121
DXC-7B	1.235	1.036	0.884	0.778	0.688	0.615	0.487	0.375	0.274	0.228	0.176
DXC-9B	1.632	1.368	1.166	1.030	0.909	0.813	0.692	0.492	0.356	0.293	0.220
DXC-11B	1.809	1.626	1.449	1.253	1.103	1.003	0.808	0.666	0.496	0.411	0.317
DXC-13B	2.171	1.930	1.718	1.495	1.318	1.194	0.964	0.787	0.588	0.486	0.371
DXC-15B	2.530	2.229	1.981	1.732	1.537	1.394	1.077	0.903	0.680	0.560	0.423
DXC-17B	2.892	2.519	2.236	1.972	1.751	1.579	1.237	1.015	0.768	0.632	0.469
DXC-19B	3.174	2.742	2.381	2.094	1.876	1.705	1.293	1.070	0.780	0.641	0.488
DXC-21B	3.710	3.163	2.756	2.417	2.152	1.958	1.595	1.305	0.867	0.712	0.563
DXC-23B	4.036	3.446	3.000	2.630	2.344	2.134	1.723	1.412	0.954	0.785	0.616
DXC-25B	4.352	3.724	3.241	2.842	2.534	2.305	1.846	1.512	1.040	0.856	0.667
DXC-27B	4.815	4.126	3.586	3.147	2.811	2.558	2.001	1.664	1.242	1.020	0.779
DXC-29B	5.125	4.399	3.822	3.353	3.000	2.729	2.087	1.761	1.307	1.068	0.813
DXC-31B	5.424	4.666	4.053	3.542	3.186	2.896	1.979	1.851	1.367	1.109	0.858
DXC-33B	5.718	4.925	4.278	3.761	3.367	3.058	2.314	1.939	1.421	1.148	0.864
DXC-35B	6.002	5.181	4.497	3.962	3.544	3.219	2.510	2.023	1.474	1.183	0.877
TO 1.67 END VOLTS PER CELL											
DXC-5B	0.908	0.758	0.653	0.566	0.501	0.451	0.344	0.265	0.187	0.156	0.121
DXC-7B	1.350	1.124	0.971	0.841	0.744	0.669	0.509	0.393	0.275	0.228	0.176
DXC-9B	1.785	1.483	1.280	1.115	0.982	0.882	0.729	0.515	0.358	0.293	0.220
DXC-11B	2.154	1.891	1.610	1.381	1.220	1.099	0.846	0.677	0.498	0.411	0.317
DXC-13B	2.585	2.239	1.902	1.641	1.449	1.299	1.000	0.804	0.590	0.486	0.371
DXC-15B	3.016	2.580	2.185	1.889	1.675	1.504	1.135	0.927	0.684	0.560	0.423
DXC-17B	3.447	2.908	2.459	2.135	1.900	1.707	1.280	1.048	0.772	0.632	0.489
DXC-19B	3.762	3.140	2.693	2.351	2.088	1.863	1.364	1.122	0.784	0.641	0.468
DXC-21B	4.327	3.646	3.133	2.720	2.409	2.160	1.655	1.327	0.871	0.712	0.563
DXC-23B	4.715	3.969	3.409	2.963	2.625	2.352	1.792	1.440	0.959	0.785	0.616
DXC-25B	5.095	4.282	3.629	3.180	2.835	2.537	1.931	1.550	1.045	0.856	0.667
DXC-27B	5.651	4.740	4.073	3.545	3.141	2.809	2.112	1.713	1.248	1.020	0.779
DXC-29B	6.026	5.050	4.337	3.777	3.349	2.994	2.234	1.820	1.314	1.068	0.813
DXC-31B	6.393	5.350	4.593	4.003	3.551	3.171	2.349	1.922	1.372	1.109	0.858
DXC-33B	6.756	5.645	4.844	4.226	3.751	3.347	2.468	2.023	1.428	1.148	0.864
DXC-35B	7.108	5.932	5.089	4.442	3.945	3.519	2.575	2.119	1.481	1.183	0.877
TO 1.60 END VOLTS PER CELL											
DXC-5B	0.931	0.780	0.671	0.582	0.511	0.456	0.349	0.266	0.187	0.156	0.121
DXC-7B	1.382	1.162	0.997	0.866	0.760	0.677	0.516	0.393	0.275	0.228	0.176
DXC-9B	1.824	1.536	1.317	1.149	1.027	0.943	0.739	0.516	0.358	0.293	0.220
DXC-11B	2.320	1.970	1.677	1.441	1.255	1.114	0.857	0.679	0.498	0.411	0.317
DXC-13B	2.783	2.344	1.985	1.713	1.496	1.327	1.014	0.806	0.590	0.486	0.371
DXC-15B	3.248	2.712	2.284	1.977	1.729	1.525	1.151	0.929	0.684	0.560	0.423
DXC-17B	3.712	3.074	2.573	2.236	1.963	1.732	1.298	1.050	0.772	0.632	0.469
DXC-19B	4.064	3.375	2.837	2.476	2.165	1.888	1.382	1.124	0.784	0.641	0.488
DXC-21B	4.672	3.857	3.248	2.819	2.478	2.203	1.677	1.330	0.871	0.712	0.563
DXC-23B	5.090	4.206	3.542	3.077	2.702	2.395	1.816	1.443	0.959	0.785	0.616
DXC-25B	5.503	4.549	3.865	3.343	2.921	2.584	1.957	1.553	1.045	0.856	0.667
DXC-27B	6.099	5.050	4.248	3.698	3.244	2.861	2.141	1.717	1.248	1.020	0.779
DXC-29B	6.508	5.391	4.535	3.951	3.463	3.044	2.264	1.824	1.314	1.068	0.813
DXC-31B	6.906	5.723	4.815	4.198	3.676	3.223	2.381	1.926	1.372	1.109	0.858
DXC-33B	7.295	6.053	5.090	4.440	3.887	3.401	2.501	2.027	1.428	1.148	0.864
DXC-35B	7.678	6.375	5.360	4.677	4.090	3.569	2.609	2.123	1.481	1.183	0.877

*KW values listed represent 100% of the initial capacity.
**At 77°F (25°C) includes intercell connector drop. All data subject to change without notice.

TYPE	5 MIN	10 MIN	15 MIN	20 MIN	25 MIN	30 MIN	45 MIN	60 MIN	90 MIN	120 MIN	180 MIN
1.215 SPECIFIC GRAVITY TO 1.75 END VOLTS PER CELL											
DXC-5	0.757	0.634	0.543	0.475	0.420	0.377	0.296	0.232	0.169	0.142	0.110
DXC-7	1.123	0.942	0.804	0.707	0.626	0.559	0.443	0.341	0.249	0.207	0.160
DXC-9	1.484	1.244	1.060	0.936	0.826	0.739	0.629	0.447	0.324	0.267	0.200
DXC-11	1.644	1.478	1.317	1.139	1.003	0.912	0.734	0.606	0.450	0.374	0.288
DXC-13	1.974	1.754	1.562	1.359	1.198	1.086	0.876	0.715	0.534	0.442	0.337
DXC-15	2.300	2.027	1.801	1.575	1.397	1.268	0.979	0.821	0.618	0.509	0.385
DXC-17	2.629	2.290	2.033	1.793	1.592	1.436	1.125	0.923	0.698	0.574	0.427
DXC-19	2.885	2.493	2.164	1.904	1.706	1.550	1.175	0.973	0.709	0.583	0.444
DXC-21	3.373	2.875	2.505	2.197	1.956	1.780	1.450	1.187	0.788	0.648	0.511
DXC-23	3.669	3.133	2.727	2.391	2.131	1.940	1.566	1.284	0.867	0.713	0.560
DXC-25	3.956	3.386	2.946	2.584	2.304	2.096	1.678	1.375	0.945	0.778	0.606
DXC-27	4.378	3.750	3.260	2.861	2.556	2.325	1.819	1.513	1.129	0.928	0.708
DXC-29	4.659	3.999	3.474	3.048	2.727	2.481	1.898	1.601	1.188	0.971	0.739
DXC-31	4.931	4.241	3.684	3.220	2.896	2.632	1.799	1.683	1.242	1.008	0.78
DXC-33	5.198	4.478	3.889	3.419	3.061	2.780	2.104	1.762	1.292	1.044	0.785
DXC-35	5.457	4.710	4.088	3.602	3.222	2.927	2.282	1.839	1.340	1.076	0.797
TO 1.67 END VOLTS PER CELL											
DXC-5	0.825	0.689	0.594	0.514	0.455	0.410	0.313	0.241	0.170	0.142	0.110
DXC-7	1.227	1.022	0.863	0.765	0.676	0.608	0.463	0.357	0.250	0.207	0.160
DXC-9	1.623	1.348	1.164	1.014	0.893	0.802	0.663	0.488	0.325	0.267	0.200
DXC-11	1.958	1.719	1.464	1.256	1.109	0.999	0.769	0.616	0.452	0.374	0.288
DXC-13	2.350	2.035	1.730	1.492	1.318	1.181	0.909	0.731	0.537	0.442	0.337
DXC-15	2.742	2.345	1.987	1.717	1.523	1.368	1.032	0.843	0.622	0.509	0.385
DXC-17	3.134	2.644	2.236	1.941	1.727	1.552	1.164	0.952	0.702	0.574	0.427
DXC-19	3.420	2.855	2.448	2.137	1.898	1.693	1.240	1.020	0.713	0.583	0.444
DXC-21	3.934	3.314	2.848	2.473	2.190	1.963	1.505	1.206	0.792	0.648	0.511
DXC-23	4.287	3.608	3.099	2.694	2.386	2.138	1.629	1.309	0.872	0.713	0.560
DXC-25	4.631	3.893	3.299	2.891	2.577	2.306	1.756	1.409	0.950	0.778	0.606
DXC-27	5.137	4.309	3.702	3.223	2.856	2.554	1.920	1.558	1.134	0.928	0.708
DXC-29	5.478	4.591	3.943	3.434	3.045	2.722	2.031	1.655	1.195	0.971	0.739
DXC-31	5.811	4.864	4.176	3.639	3.228	2.883	2.136	1.747	1.247	1.008	0.780
DXC-33	6.142	5.132	4.404	3.842	3.410	3.043	2.243	1.839	1.299	1.044	0.785
DXC-35	6.462	5.393	4.626	4.038	3.586	3.199	2.341	1.926	1.347	1.076	0.797
TO 1.60 END VOLTS PER CELL											
DXC-5	0.847	0.710	0.610	0.529	0.465	0.415	0.317	0.242	0.170		

Capacities - Dimensions - Weights

TYPE*	NOM. Ah CAP.†	OVERALL DIMENSIONS						WEIGHTS - VOLUMES							
		L**		W		H		UNPACKED		DOMESTIC PACKED		ELECTROLYTE ONLY 1.215 S.G.			
		in	mm	in	mm	in	mm	lbs	kgs	lbs	kgs	lbs	kgs	gal	/
4DXC-5	214	9.50	241	16.00	406	22.00	558	256.0	116.4	263.0	119.5	80.0	36.4	7.5	28.4
4DXC-7	308	9.50	241	16.00	406	22.00	558	303.0	137.7	312.0	141.8	70.0	31.8	6.7	25.4
4DXC-9	402	9.50	241	16.00	406	22.00	558	353.0	160.5	363.0	152.7	63.0	28.6	6.0	2
4DXC-11	542	16.70	424	16.00	406	22.68	576	507.0	230.5	522.0	237.3	146.0	66.4	14.0	53.0
4DXC-13	629	16.70	424	16.00	406	22.68	576	557.0	253.2	573.0	260.4	138.0	62.7	13.0	49.2
4DXC-15	709	16.70	424	16.00	406	22.68	576	606.0	275.5	624.0	283.6	130.0	59.1	12.5	47.3
4DXC-17	778	16.70	424	16.00	406	22.68	576	656.0	298.2	675.0	306.8	122.0	55.4	11.8	44.7
2DXC-19	796	9.50	241	16.00	406	22.68	576	373.0	169.5	384.0	174.5	67.0	30.4	6.5	24.6
2DXC-21	883	12.12	308	16.00	406	22.68	576	448.3	203.8	463.3	210.6	93.3	42.4	8.97	33.9
2DXC-23	977	12.12	308	16.00	406	22.68	576	473.3	215.1	489.3	222.4	89.3	40.6	8.58	32.4
2DXC-25	1063	12.12	308	16.00	406	22.68	576	499.3	227.0	515.3	234.2	85.3	38.8	8.20	31.0
2DXC-27	1331	16.70	424	16.00	406	22.68	576	587.0	266.8	604.0	274.5	143.0	65.0	13.7	51.8
2DXC-29	1385	16.70	424	16.00	406	22.68	576	613.0	278.6	632.0	287.2	139.0	63.1	13.3	50.3
2DXC-31	1416	16.70	424	16.00	406	22.68	576	638.0	290.0	657.0	298.6	135.0	61.4	12.9	48.8
2DXC-33	1471	16.70	424	16.00	406	22.68	576	663.0	301.4	682.0	310.0	130.0	59.1	12.5	47.3
2DXC-35	1505	16.70	424	16.00	406	22.68	576	680.0	309.0	700.0	318.2	126.0	57.3	12.1	45.8

* Suffix Number indicates Total Plates Per Cell.

** 0.25" must be added between units for spacing purposes when calculating total battery length.

†Nominal Amp hour capacity at the 8-hour rate.

All data subject to change without notice

Accessories

†CELL NUMBER SET	1-12	802360
	1-24	802361
	1-60	802362
	1-120	802363
	1-240	802364
	1-300	802365
†PORTABLE HYDROMETER		81332
†HYDROMETER HOLDER - WALL MOUNT		27717
†THERMOMETER		88330
(Portable or Flame Arrestor Mounting)		
FLAME ARRESTOR (Supplied With Each Cell)		96300
†Included with each system		

Slide-Lock™ Post Seal

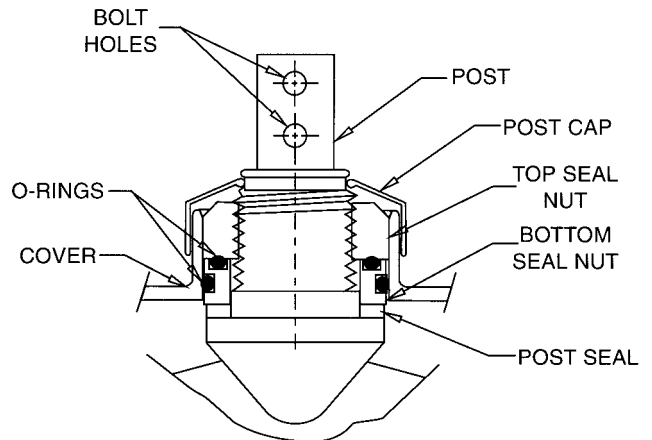

NOTE: All inter-cell, inter-tier, inter-step, end-to-end inter-rack, back-to-back inter-rack connectors, terminal lugs, and terminal plates are included with every battery. Across-aisle inter-rack connectors are not included.

Represented by:

When ordering new batteries, also remember to properly recycle your old lead batteries. Federal and state regulations require lead-acid batteries be recycled. EnerSys' nationwide service organization can arrange pickup, transportation to and recycling at any one of our company affiliated smelters. Call 1-800-972-7372 for more information.



Corporate Office: P.O. Box 14145, Reading, PA 19612-4145
610-208-1991 • 800-538-3627
FAX 610-372-8613

Sales Offices
Eastern Region: 215-491-3700 • 800-346-4402
FAX 215-491-2304

Western Region: 510-887-2046 • 888-887-2046
FAX 510-887-6309

International: 610-208-1847
FAX 610-208-1851

EnerSys Canada: 905-790-1212
FAX 905-790-7070

EnerSys Argentina: 54-1-736-3000
FAX 54-1-736-3200

EnerSys de Mexico: 52-83-656-620
FAX 52-83-656-621

Acumuladores Navit S.A., Brazil: 55-11-6412-7522
FAX 55-11-6481-4019

Visit us on the web at: www.enersysstationary.com

Please check our website for literature updates

Printed in USA