

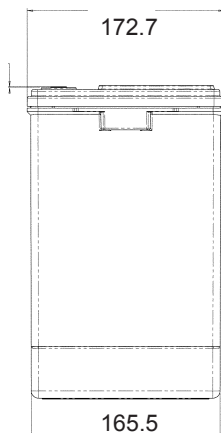

12V 539.7 watts/cell
at 4C (15 min.) rate

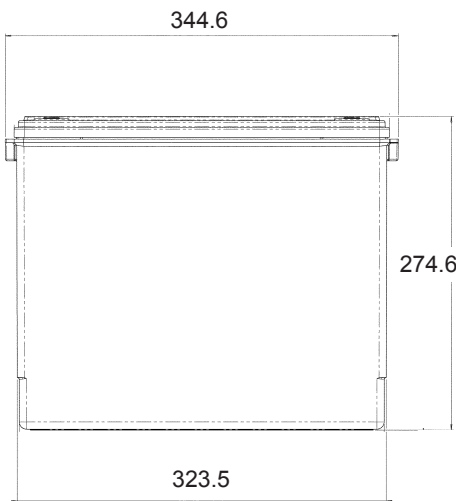

KEY FEATURES

Specifically designed and engineered for mission critical applications

- Performance excels at high rates of discharge and recharge
- 3 year warranty
- Advanced automation in manufacturing processes ensure consistency and reliability
- Advanced AGM materials significantly enhance performance and reliability
- Exceptional performance under deep or shallow cyclic discharge applications
- Operational within an extreme temperature range
- High cyclic capability +500 C/3 at 80% Depth of Discharge
- Advanced 3 stage terminal design to ensure leak free operation
 - - Female M6 brass terminals provide maximum performance
- Thermally sealed PC/ABS plastic casing and cover
 - - Flame retardant (UL 94 VO) and LOI of at least 28%
 - - Designed to withstand extreme degrees of temperature and pressure
- Approved as non-hazardous cargo for ground, sea and air transport
 - - DOT 49CFR173.159(d), (i) and (ii)
- All NorthStar products are compliant with
 - - Telcordia SR4228, Bellcore GR-63-Core, Issue 1
 - - British and German telecom standards
 - - UL Approved
- Northstar is Registered to ISO 9001: 2000 & ISO 14001: 1996

ELECTRICAL CHARACTERISTICS

	NA Standards (77°F) □	Int'l Standards (20°C)
4C (15 min.) Power to 1.67 VPC □	539.7 watts per cell □	506.0 watts per cell □
Float Voltage □	2.27 +/- 0.02 volts per cell □	2.29 +/- 0.02 volts per cell □
Cyclic Recharge □	2.45 VPC (no limit on current)	
Shelf Life □	2 years	
Impedance (1KHz) □	0.0020 ohms □	
Short Circuit Current □	5300 Amps □	
Nominal Voltage □	12 Volts □	

CONSTANT POWER DISCHARGE RATINGS

End of Discharge (Volts)	watts/cell at 25°C (77°F)								
	Duration (minutes)								
	2	5	10	15	20	30	45	60	120
1.75	1105.2	836.4	612.4	492.0	414.9	319.8	241.1	194.9	112.4
1.70	1190.0	900.8	655.2	523.4	439.3	336.1	251.5	202.2	115.0
1.67	1232.8	934.1	677.5	539.7	451.9	344.6	256.8	205.9	116.4
1.65	1257.5	953.8	690.7	549.4	459.5	349.6	260.0	208.1	117.2
1.60	1304.3	992.9	717.5	569.2	474.8	359.8	266.4	212.5	118.7

MECHANICAL CHARACTERISTICS

	SI Units □	English Units
Height □	274.6 mm □	10.80 inches □
Width □	172.7 mm □	6.80 inches
Length □	344.7 mm □	13.60 inches
Weight □	49.7 kilograms □	109.5 pounds
Terminal Torque □	8.0 Newton-meters □	71 inch-pounds

CONSTANT CURRENT DISCHARGE RATINGS

End of Discharge (Volts)	Amperes at 25°C (77°F)								
	Duration (minutes)								
	2	5	10	15	20	30	45	60	120
1.75	627.8	461.5	330.6	262.4	219.4	167.2	124.7	100.1	56.8
1.70	682.0	501.6	356.9	281.5	234.2	177.1	131.0	104.5	58.5
1.67	709.8	522.6	370.7	291.6	242.0	182.2	134.2	106.8	59.3
1.65	726.1	535.1	379.0	297.6	246.6	185.3	136.2	108.1	59.8
1.60	757.5	560.4	395.9	309.9	256.2	191.6	140.1	110.8	60.8

For additional current, capacity and power information refer to the NSB detailed performance tables.