

Single Frequency Modular Ringing Supplies

Key Features

- **Compact**—requires only 7" (17.78cm) of vertical rack space
- **Flexible**—50VA - 172VA ringing capacity
- **Reliable**—redundant operating configuration
- **Field Adjustable Voltage and Frequency**—for special applications
- **At-a-Glance Status**—LED indicators provide easy system status review
- **AC/DC AUDIBLE**—available with superimposed, precise ringing tone for AC/DC AUDIBLE ringing current for central office "Special Services" equipment requiring this feature

Description

The Lorain® SFT2 and SFT6 single frequency transfer cabinets are compact, modular shelf units that can be easily configured to provide 50 to 172VA ringing capacity from a -48 VDC source for a wide range of central office applications. The modular design enables fast field expansion and simple replacement for service without system shutdown.

Application

The SFT2 or SFT6 transfer cabinet equipped with 50VA or 86VA modular ringing generators is ideal for a wide range of central office residual ringing load or general-purpose applications where the ambient temperature is within the range of -9.5° C to +54.5° C (+15° F to +130° F).

The System

Transfer Cabinets

The SFT2 system consists of a 19" (48.26cm) wide x 7" (17.78cm) high shelf unit containing transfer and alarm relays and a transfer module. The system can accommodate two modular ringing generator units and an optional tone generator module or digital meter module. This system can deliver 50VA with backup (two 50VA generators) or 86VA with backup (two 86VA generators) as illustrated in Figures 1, 2 and 3. Adapter plates for mounting the SFT2 in a 23" (58.42cm) relay rack are included as standard equipment. The adapter plates may be discarded when mounting the SFT2 in a 19" (48.26cm) relay rack.

The SFT6 system consists of a 23" (58.42cm) wide x 7" (17.78cm) high shelf unit containing transfer and alarm relays and a transfer module. The system can accommodate two or four modular ringing generator units. This system can deliver 50VA with backup (two 50VA generators), 100VA with backup (four 50VA generators), 86VA with backup (two 86VA generators) or 172VA with backup (four 86VA generators).

Transfer Cabinet Common Characteristic

The transfer module within the SFT2 or SFT6 permits selection of the generators on either the Number 1 or Number 2 side of the system to carry the load. The generators on the opposite side automatically become the standby or "backup" units.

Both main and standby generators are continuously supervised for low output voltage. If the main generator fails, the transfer circuit switches the load to the standby generator and issues a local and remote minor alarm. If the standby generator fails after it assumes the load, a local and remote major alarm is issued. If the standby generator fails while the main generator is carrying the load, a local and remote minor alarm is issued.



Single Frequency Modular Ringing Supplies

The System (continued)

Transfer module LED indicators display the on-line status of the Number 1 or Number 2 ringing generators as well as generator failure, major and minor alarm status, and fuse alarm status.

Both SFT2 and SFT6 shelf units have customer input, output and alarm connections made to terminal blocks located on the rear of the system cabinet. An accessory input/output termination panel and wiring harness is available for SFT6 shelf units intended for front-access installation. Mounts in a 1.75" (4.45cm) x 23" (58.42cm) rack space directly above the SFT6.

50VA Modular Ringing Generators

The T50P and T50PT ringing generator modules operate from -48 VDC, and each provides up to 50VA of ringing power. The standard factory adjustments set the output frequency and voltage at 20 Hz and 86V rms, respectively. If required by local conditions, the frequency can be easily reset, in RUS* recommended discrete steps, from 15 to 67 Hz. The output voltage is continuously adjustable from 65-90 or 90-155V rms by output transformer tap selection and a front panel voltage control adjustment.

When used in transfer cabinets with expansion capability, such as the SFT6, two T50P units may be operated in parallel to double the available output power from 50VA to 100VA.

The T50PT is essentially identical to the T50P, with the addition of an internal tone generator that superimposes a 440+480 Hz precise audible ringing tone on the output waveshape for "AC/DC AUDIBLE" ringing. If parallel operation of the T50PT is desired for increased output capacity, only the main generator needs to be a T50PT. The redundant unit can be a standard T50P.

The typical -48V input current for T50-type generators is 0.25 amp per module during light-load periods or standby operation, and 1.65 amps per on-line module during full-load periods. Dedicated "A" and "B" -48V power feeders are recommended for each side of the system.

86VA Modular Ringing Generators

The T86 and T86T ringing generator modules operate from -48 VDC, and each provides up to 86VA of ringing power. The standard factory adjustments set the output frequency and voltage at 20 Hz and 86V rms, respectively. If required, the frequency can be easily reset to 25 Hz to conform to CCITT (International Telecommunications) standards. The output voltage is continuously adjustable from 65-90V rms by a front panel voltage control adjustment. The maximum available output current is 1 amp for any voltage setting below 86V rms.

When used in transfer cabinets with expansion capability, such as the SFT6, two T86 units may be operated in parallel to double the available output power from 86VA to 172VA.

The T86T is essentially identical to the T86 with the addition of an internal tone generator that superimposes a 440+480 Hz precise audible ringing tone on the output waveshape for "AC/DC AUDIBLE" ringing. If parallel operation of the T86T is desired for increased output capacity, only the main generator needs to be a T86T. The redundant unit can be a standard T86.

The typical -48V input current for T86-type generators is 0.25 amp per module during light-load periods or standby operation, and 2.6 amps per on-line module during full-load periods. Dedicated "A" and "B" -48V power feeders are recommended for each side of the system.

Ring Generator Common Characteristics

All Lorain T50P and T86 type generators feature either analog microchip or crystal-controlled digital waveform generation for precise, drift-free control of output frequency. The output waveform is a clean sine-wave featuring low harmonic distortion and excellent voltage regulation (typically $\pm 2\%$) with both input battery and output loading variations. All units are factory-adjusted for 20 Hz, 86V rms operation and can be easily readjusted in the field if local conditions require a different frequency or voltage setting.

Single Frequency Modular Ringing Supplies

The System (continued)

Each generator has a *generator on* LED indicator and an *output overload* LED, which indicates when the output voltage has been automatically reduced due to an overload condition. If the generator output fails, an alarm is extended to the transfer unit included with the SFT2 or SFT6 transfer cabinet and the ringing load is automatically transferred to the standby generator(s) to assure continuous service. Test jacks on the generator front panel provide a convenient means of checking the generator output voltage and frequency.

Configuration

Figure 1 — SFT2 Redundant 50VA System

T50P Ringing Generator (Main) G-1	T50P Ringing Generator (Standby) G-2	Transfer Module (Included)	* Space for Tone Generator or Meter Module
--	---	---	---

Specify one SFT2 transfer cabinet, spec. number 585100200 factory equipped with two model T50P (50VA) ringing generator plug-in modules spec. number 487110400.

Cabinet Size:

19" (48.26cm) wide, 15" (38.1cm) deep, 7" (17.78cm) high

*Order accessory tone generator or Meter Module per "Accessory" Descriptions

Figure 2 — SFT2 Redundant 86VA System

T86 Ringing Generator (Main) G-1	T86 Ringing Generator (Standby) G-2	Transfer Module (Included)	* Space for Tone Generator or Meter Module
---	--	---	---

Specify one SFT2 transfer cabinet, spec. number 585100200 factory equipped with two model T86 (86VA) ringing generator plug-in modules, spec. number 487110600.

Cabinet Size:

19" (48.26cm) wide, 15" (38.1cm) deep, 7" (17.78cm) high

*Order accessory tone generator or Meter Module per "Accessory" Descriptions

Figure 3 — SFT2 Redundant 86VA System for "AC/DC AUDIBLE" Ringing

T86T Ringing Generator (Main) G-1	T86T Ringing Generator (Standby) G-2	Transfer Module (Included)	* Space for Tone Generator or Meter Module
--	---	---	---

Specify one (1) SFT2 transfer cabinet, spec. number 585100200 factory equipped with two (2) model T86T (86VA) ringing generator plug-in modules, spec. number 487110800.

Cabinet Size:

19" (48.26cm) wide, 15" (38.1cm) deep, 7" (17.78cm) high

*Order accessory tone generator or Meter Module per "Accessory" Descriptions

Single Frequency Modular Ringing Supplies

Configuration (continued)

Accessory Tone Generators for SFT2

TABLE A ACCESSORY TONE GENERATORS FOR SFT2		
Type	Frequency (Hz)	Spec. No.
Dial Tone	350+440	487137100
High Tone	480	487136500
Low Tone	480+620	487136400

For "Special Services" (non-switched load) applications requiring a low-power source of dial tone, high tone or low tone. Order per Table A for SFT2 transfer cabinets only. Consists of dual (main and standby) 0.1VA precise tone generators with automatic and manual transfer, assembled in a single, compact plug-in unit. This accessory is not available when a List B meter module (see below) is used.

Accessory Digital Meter Module for SFT2

Provides for the measurement and display of the output frequency and voltage of either ringing generator (G-1 or G-2) or the office load output of the transfer circuit. Specify "List B Meter Module." For SFT2 transfer cabinets only. This accessory is not available when an optional tone generator per Table A above (or equal) is used.

SFT6 Redundant 50-172VA System

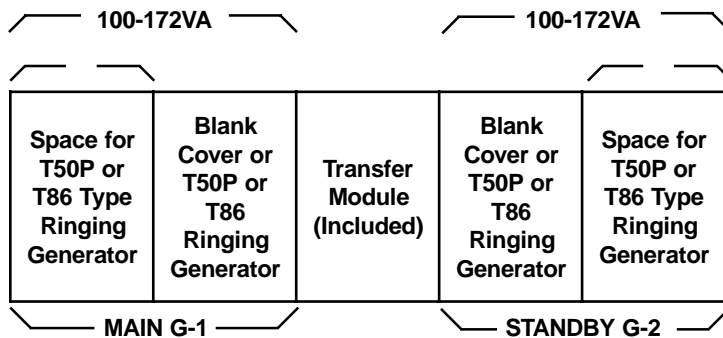

Specify one SFT6 transfer cabinet, factory equipped with ringing generator plug-in modules per Table C. This cabinet accommodates two or four 50VA or 86VA modules.

Cabinet Size:
23" (58.42cm) wide, 15" (38.1cm) deep, 7" (17.78cm) high.

†50VA when using T50P generators, 86VA when using T86-type generators. See Table C.

Additional Information

For additional specifications, engineering and installation information, specify model number and spec. number per configuration information listed in previous section.



www.marconi.com/power
Marconi Communications
 1122 F Street
 Lorain, OH 44052
 800-800-1280
 Fax: 440-246-4876

Lorain® is a trademark of Marconi Communications Inc.
 © 2000 Marconi Communications Inc.
 Printed in the USA. All rights reserved. Any unauthorized reproduction or transmission without the prior consent of Marconi Communications Inc. is prohibited.