



## ***PS-19 TwinPack® Power Systems***

### **GENERAL.**

The *PS-19 TwinPack®* Power System is a modular power system designed to provide a variety of power outputs for telecommunications loads. The *PS-19* offers tremendous size and weight reductions over presently used ferroresonant technology.

The *PS-19* mounting shelf is 5-1/4" (13 cm) high x 19" (48 cm) wide x 13.5" (34 cm) deep and will accommodate single or dual rectifier or ringing generator modules. Outputs of -48 volts DC,  $\pm 24$  volts DC, or +12 volts DC, and 90-105 volts, 20 Hz AC (ringing) are presently available. All modules are connectorized and plug in from the front. The backplane circuit boards are designed to accept the entire variety of plug-in modules. The mounting shelf is designed for standard 19" (48 cm) or 23" (58 cm) relay rack mounting.

All rectifier circuitry uses 100 KHz MOSFET technology, with the ringing generator using ferroresonant technology.

### **FEATURES.**

- Plug-in power modules.
- 1200 watts of power in 5-1/4" (13 cm) high x 19" (48 cm) wide mounting shelf with a total weight of less than 25 lbs. (11 kg).
- Conducted and radiated noise conforms to FCC Part 15, Subpart B, Class A.
- Meets international input harmonic current requirements of Telcordia Technologies GR-1089.
- Complies with applicable portions of Telcordia Technologies GR-967.
- Successfully passed seismic testing in accordance with Telcordia Technologies GR-63-CORE (zone 4).
- UL Listed (UL 1012) Model *PS-19*.
- Bears the UL mark for Canada (CAN/CSA-C22.2 No. 107.9-M91).
- UL Recognition (UL 1459) Model *PS-19UR*.
- Ambient temperature range of 0 to +50°C (32°F to 122°F) at 0 to 95% relative humidity. Operation at altitudes of up to 10,000 feet. NOTE: Extended temperature models are available for operation from -40°C to +65°C (-40°F to 149°F) ambient.
- Convection cooling (no fans).



**Figure 1. Front View of *PS-19 TwinPack* Power System.**

- Rectifier modules can accept an AC input of 95 volts to 132 volts and 180-264 volts, 47-63 Hz, single-phase.
- Rectifier modules include active power factor correction circuitry. Input power factor is 0.95 from 50% to 100% load. (Note: The following models are not power factor corrected: MOD 487.5, MOD 487.5P, MOD 487.5PC, MOD 487.5PCA, MOD 4806T, MOD 4806TP, MOD 4806TPCA, MOD 12N7.5TP, and MOD 24N7.5TP).
- All protective devices are circuit breakers. No fuses required.
- Each rectifier module is supplied with one Standard North American 15 A Power Cord (12 Ft.) with NEMA 5-15P Connector. Other types of line cord sets can be furnished; contact the factory.
- 40 Amp rated output terminal block.
- Separate alarm terminal block for remote alarms.
- LEDs for output failure alarm (red) and input on (green).
- Form "C" contacts for output failure alarm.
- Rectifier modules include high output DC voltage shutdown with auto restart, output voltage adjustment, and temperature compensated current limiting.
- Blocking diode included on all rectifier modules.
- Output voltage test points mounted on the front.
- International rectifier modules available for operation from 95 volts to 264 volts AC input, 45-65 Hz single phase.
- International versions are available with a 20 Ampere AC terminal block.



**Figure 2. Rear View – Cover Removed.**

## RECTIFIER ASSEMBLIES

Each Rectifier Module (-48 VDC,  $\pm 24$  VDC, or +12 VDC) consists of three (3) plug-in circuit boards, except the following, which consist of "A" and "C" boards only: MOD 487.5, MOD 487.5P, MOD 487.5PC, MOD 487.5PCA, MOD 4806T, MOD 4806TP, MOD 4806TPCA, MOD 12N7.5TP, and MOD 24N7.5TP.

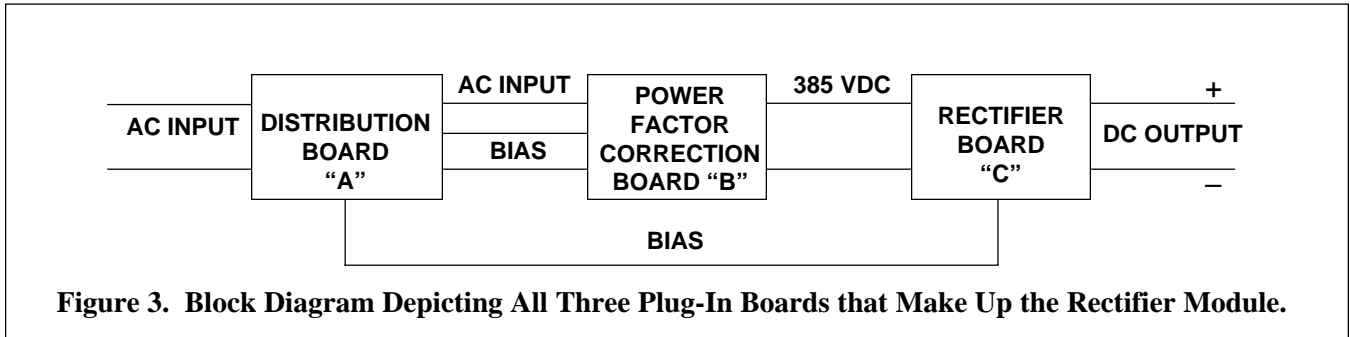

- |   |  |
|---|--|
| <p><b>"A" Board – Distribution Board</b></p>                  | <p>Consists of EMI filter, bias supply, alarm relay and connector, input breaker, and input connector.</p>                       |
| <p><b>"B" Board – Power Factor Correction (PFC Board)</b></p> | <p>Consists of bridge rectifier and power factor correction circuitry. The PFC board provides a regulated output of 385 VDC.</p> |
| <p><b>"C" Board – Rectifier Board</b></p>                     | <p>Converts a DC input of 385 VDC to the proper output (-48 VDC, <math>\pm 24</math> VDC, or +12 VDC).</p>                       |

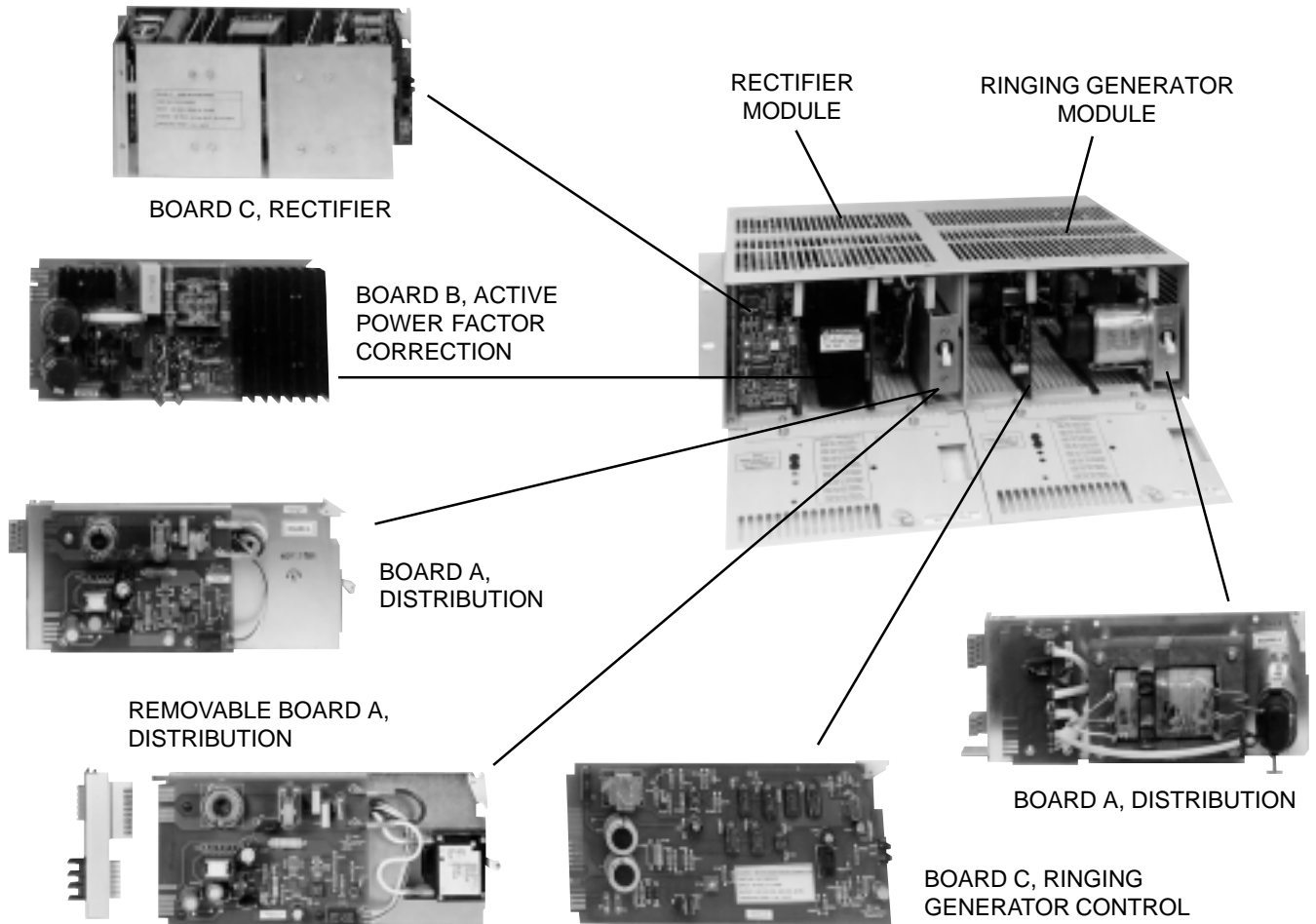

**Input Harmonic Current.**

The rectifier meets the requirements of Telcordia Technologies GR-1089.

**Adjustable High Voltage Shutdown with Auto Restart.**

The rectifier module will shut down and attempt to restart itself if the output voltage exceeds a preset value (adjustable in 0.5V increments, e.g. 48 VDC is adjustable from 55.0 to 58.5 VDC). After the rectifier attempts to restart, if the high voltage condition still exists, the rectifier will latch off. To restart the rectifier, recycle the input power.

**Input Protection.**

15 Ampere single pole circuit breaker which is accessed from the front with a circuit breaker guard.

**Alarms.**

Rectifier module failure alarm senses the output voltage and operates one set of Form "C" contacts for remote alarm if the output voltage is outside its normal operating range (low end 47V, high end 54.5V, - 48 VDC models). A front panel red LED is furnished to indicate a failure. A green LED is furnished to indicate normal operation.

**Filtering.**

Output ripple is less than 100 mV peak to peak (DC to 20 MHz bandwidth).

Output ripple is less than 200 mV peak to peak (DC to 100 MHz bandwidth).

Output noise is less than 26 dB<sub>Brn-c</sub> measured on a 3A noise measurement set, without a battery connected.

**Parallel Operation.**

Inherent when the output voltages of all units are adjusted to the same value.

**Output Diode.**

A blocking diode in the ungrounded side of the output is provided to prevent a faulted rectifier from affecting the output bus.

**Voltage Adjust and Test Points.** Located on the front.

**EMI.** The rectifier meets FCC regulation Part 15, Subpart B, Class A.

**Output Protection Temperature Compensated Current Limiting (Standard 48 VDC Models).**

Output current is automatically limited to 12.7 Amperes from 0°C to +40°C (32°F to 104°F) Ambient and 10.5 Amperes from +41°C to +50°C (106°F to 122°F) Ambient. The rectifier is shut down if the ambient reaches 55°C. Ambient temperature is sensed at the bottom of the mounting shelf.

**Output Protection Temperature Compensated Current Limiting (Extended Temperature 48 VDC Models).**

Output current is automatically limited to 10.5 Amperes from -40°C to +50°C (-40°F to 122°F) Ambient and 8.0 Amperes from +51°C to +65°C (124°F to 149°F) Ambient. The rectifier is shut down if the ambient reaches +70°C (158°F). Ambient temperature is sensed at the bottom of the mounting shelf.

**Temperature Compensation Connection.** All rectifier modules with a "C" in their model number have the temperature compensated battery charging feature. Terminal block TB2 position 2 (TC) provides the external connection required from the rectifier to the thermal monitor and control panel. Terminal block TB2 is a plug-in terminal block that is removed by grasping the top and bottom and pulling it out of the mating receptacle. Removing the terminal block will facilitate connecting the wires. Factory assembled cables are provided for connection between thermal monitor and control panel post headers P10 through P13 and the rectifier. The cables have one two-position post header connection at one end with two wires connected. Each of these two wires has a separate post header connector affixed at the other end. Using the cable set provided, connect the two-wire, two-position connector to the post header P10 through P13 as required on the thermal monitor and control panel. Route the cable set to the *PS-19* rectifier and connect to TB2 pin 2 (TC) as required. See manual IM8850000011 for the Thermal Monitor and Control Panel for connection details.

**Front Access Removable "A" Board.** All rectifiers having an "A" in the model number feature the front access removable "A" board. This board is divided into two sections that plug together via connectors. Section one contains the AC input terminal block, alarm connection terminal block, and a tapped hole for the board grounding screw. Section two contains the EMI filter, bias supply, alarm relay and input circuit breaker. This section is removable from the front of the mounting shelf. See IM9144100205, Rev. 13 or later, for installation details.

## Standard Rectifier Model Specifications.

Rectifier Module	STANDARD MODELS			
<b>Model Number</b>	MOD 4812	MOD 487.5	MOD 2420	MOD 24N20
<b>Part Number</b>	9144100205	9144100212	9144100201	9144100202
<b>Input Voltage Range</b>	95 to 132 VAC	95 to 132 VAC	95 to 132 VAC	95 to 132 VAC
<b>Input Frequency Range</b>	45 to 65 Hz	45 to 65 Hz	45 to 65 Hz	45 to 65 Hz
<b>Output Voltage</b>				
<b>Range</b>	-43 to -56 VDC	-43 to -56 VDC	-21 to -28 VDC	+21 to +28 VDC
<b>Setting</b>	-52 VDC	-52 VDC	-26 VDC	+26 VDC
<b>Output Current</b>	12 A (0°C to +40°C) (32°F to 104°F)	7.5 A (0°C to +40°C) (32°F to 104°F)	20 A (0°C to +40°C) (32°F to 104°F)	20 A (0°C to +40°C) (32°F to 104°F)
	10 A (+41°C to +50°C) (106°F to 122°F)	6 A (+41°C to +50°C) (106°F to 122°F)	17.5 A (+41°C to +50°C) (106°F to 122°F)	17.5 A (+41°C to +50°C) (106°F to 122°F)
<b>Efficiency, All Input Line Conditions</b>				
<b>50% to 100% Load</b>	80%	85%	80%	80%
<b>Power Factor, All Input Line Conditions</b>				
<b>50% to 100% Load</b>	0.95	0.6	0.95	0.95
<b>Regulation, All Input Line Conditions</b>				
<b>10% to 100% Load</b>	±0.5%	±0.5%	±0.5%	±0.5%
<b>No Load to 100% Load</b>	±1.0%	±0.5%	±0.5%	±0.5%
<b>Input Current</b>				
<b>95 VAC</b>	7.9 A	7.7 A	6.5 A	6.5 A
<b>120 VAC</b>	6.0 A	6.1 A	5.0 A	5.0 A
<b>132 VAC</b>	5.5 A	5.6 A	4.5 A	4.5 A
<b>180 VAC</b>	N/A	N/A	N/A	N/A
<b>220 VAC</b>	N/A	N/A	N/A	N/A
<b>264 VAC</b>	N/A	N/A	N/A	N/A
<b>Output Power</b>	600 Watts	375 Watts	500 Watts	500 Watts
<b>Heat Dissipation</b>				
<b>at 120 VAC</b>	450 BTU/Hr.	200 BTU/Hr.	350 BTU/Hr.	350 BTU/Hr.
<b>at 220 VAC</b>	N/A	N/A	N/A	N/A
<b>For use in Mounting Shelf (Part Number)</b>	7001900010 (UL) 7001900025 (UR)	7001900010 (UL) 7001900025 (UR)	7001900010 (UL) 7001900025 (UR)	7001900010 (UL) 7001900025 (UR)
<b>Circuit Board Assembly Part Numbers</b>				
<b>Board A</b>	0000910201	0000916643	0000910201	0000910201
<b>Board B</b>	0000910199	-----	0000910199	0000910199
<b>Board C</b>	0000910178	0000916639	0000916603	0000916604

Note: All rectifiers are UL Listed (UL 1012), UL Recognized (UL 1459) and bear the UL mark for Canada (tested and certified by UL to be in compliance with Canada's CAN/CSA-C22.2 No. 107.9-M91 Standard for Commercial and Industrial Power Supplies).

**Standard Extended Temperature Rectifier Model Specifications (continued).**

<b>Rectifier Module</b>	<b>STANDARD EXTENDED TEMPERATURE MODELS</b>			
<b>Model Number</b>	MOD 4810T	MOD 4806T	MOD 2417T	MOD 24N17T
<b>Part Number</b>	9144100206	9144100213	9144100207	9144100208
<b>Input Voltage Range</b>	95 to 132 VAC	95 to 132 VAC	95 to 132 VAC	95 to 132 VAC
<b>Input Frequency Range</b>	45 to 65 Hz	45 to 65 Hz	45 to 65 Hz	45 to 65 Hz
<b>Output Voltage</b>				
<b>Range</b>	-43 to -56 VDC	-43 to -56 VDC	-21 to -28 VDC	+21 to +28 VDC
<b>Setting</b>	-52 VDC	-52 VDC	-26 VDC	+26 VDC
<b>Output Current</b>	10 A (-40°C to +50°C) (-40°F to 122°F) 7.5 A (+51°C to +65°C) (124°F to 149°F)	6 A (-40°C to +50°C) (-40°F to 122°F) 5 A (+51°C to +65°C) (124°F to 149°F)	17.5 A (-40°C to +50°C) (-40°F to 122°F) 12.5 A (+51°C to +65°C) (124°F to 149°F)	17.5 A (-40°C to +50°C) (-40°F to 122°F) 12.5 A (+51°C to +65°C) (124°F to 149°F)
<b>Efficiency, All Input Line Conditions</b>				
<b>50% to 100% Load</b>	80%	85%	80%	80%
<b>Power Factor, All Input Line Conditions</b>				
<b>50% to 100% Load</b>	0.95	0.6	0.95	0.95
<b>Regulation, All Input Line Conditions</b>				
<b>10% to 100% Load</b>	±0.5%	±0.5%	±0.5%	±0.5%
<b>No Load to 100% Load</b>	±1.0%	±0.5%	±0.5%	±0.5%
<b>Input Current</b>				
<b>95 VAC</b>	6.5 A	6.2 A	5.6 A	5.6 A
<b>120 VAC</b>	5.0 A	4.9 A	4.4 A	4.4 A
<b>132 VAC</b>	4.5 A	4.5 A	4.0 A	4.0 A
<b>180 VAC</b>	N/A	N/A	N/A	N/A
<b>220 VAC</b>	N/A	N/A	N/A	N/A
<b>264 VAC</b>	N/A	N/A	N/A	N/A
<b>Output Power</b>	500 Watts	300 Watts	440 Watts	440 Watts
<b>Heat Dissipation</b>				
<b>at 120 VAC</b>	350 BTU/Hr.	165 BTU/Hr.	325 BTU/Hr.	325 BTU/Hr.
<b>at 220 VAC</b>	N/A	N/A	N/A	N/A
<b>For use in Mounting Shelf (Part Number)</b>	7001900010 (UL) 7001900025 (UR)	7001900010 (UL) 7001900025 (UR)	7001900010 (UL) 7001900025 (UR)	7001900010 (UL) 7002900025 (UR)
<b>Circuit Board Assembly Part Numbers</b>				
<b>Board A</b>	0000916550	0000916667	0000916550	0000916550
<b>Board B</b>	0000916539	-----	0000916539	0000916539
<b>Board C</b>	0000916542	0000916668	0000916636	0000916633

Note: All rectifiers are UL Listed (UL 1012), UL Recognized (UL 1459) and bear the UL mark for Canada (tested and certified by UL to be in compliance with Canada's CAN/CSA-C22.2 No. 107.9-M91 Standard for Commercial and Industrial Power Supplies).

## International Rectifier Model Specifications.

Rectifier Module	INTERNATIONAL MODELS			
<b>Model Number</b>	MOD 4812P	MOD 487.5P	MOD 487.5PC*	MOD 487.5PCA
<b>Part Number</b>	9144100216	9144100220	9144100227	9144100231
<b>Input Voltage Range</b>	95 to 264 VAC	95 to 132 VAC 180 to 264 VAC	95 to 132 VAC 180 to 264 VAC	95 to 132 VAC 180 to 264 VAC
<b>Input Frequency Range</b>	45 to 65 Hz	45 to 65 Hz	45 to 65 Hz	45 to 65 Hz
<b>Output Voltage</b>				
<b>Range</b>	-43 to -56 VDC	-43 to -56 VDC	-43 to -56 VDC	-43 to -56 VDC
<b>Setting</b>	-52 VDC	-52 VDC	-52 VDC	-52 VDC
<b>Output Current</b>	12 A (0°C to +40°C) (32°F to 104°F) 10 A (+41°C to +50°C) (106°F to 122°F)	7.5 A (0°C to +40°C) (32°F to 104°F) 6 A (+41°C to +50°C) (106°F to 122°F)	7.5 A (0°C to +40°C) (32°F to 104°F) 6 A (+41°C to +50°C) (106°F to 122°F)	7.5 A (0°C to +40°C) (32°F to 104°F) 6 A (+41°C to +50°C) (106°F to 122°F)
<b>Efficiency, All Input Line Conditions</b> <b>50% to 100% Load</b>	80%	85%	85%	85%
<b>Power Factor, All Input Line Conditions</b> <b>50% to 100% Load</b>	0.95	0.6	0.6	0.6
<b>Regulation, All Input Line Conditions</b>				
<b>10% to 100% Load</b>	±0.5%	±0.5%	±0.5%	±0.5%
<b>No Load to 100% Load</b>	±1.0%	±0.5%	±0.5%	±0.5%
<b>Input Current</b>				
<b>95 VAC</b>	7.9 A	7.7 A	7.7 A	7.7A
<b>120 VAC</b>	6.0 A	6.1 A	6.1 A	6.1 A
<b>132 VAC</b>	5.5 A	5.6 A	5.6 A	5.6 A
<b>180 VAC</b>	4.0 A	3.5 A	3.5 A	3.5 A
<b>220 VAC</b>	3.3 A	2.8 A	2.8 A	2.8 A
<b>264 VAC</b>	2.9 A	2.3 A	2.3 A	2.3 A
<b>Output Power</b>	600 Watts	375 Watts	375 Watts	375 Watts
<b>Heat Dissipation</b>				
<b>at 120 VAC</b>	450 BTU/Hr.	200 BTU/Hr.	200 BTU/Hr.	200 BTU/Hr.
<b>at 220 VAC</b>	500 BTU/Hr.	200 BTU/Hr.	200 BTU/Hr.	200 BTU/Hr.
<b>For use in Mounting Shelf (Part Number)</b>	7001900016 (UL)	7001900016 (UL)	7001900016 (UL)	7001900016 (UL)
<b>Circuit Board Assembly Part Numbers</b>				
<b>Board A</b>	0000916887	0000916907	0000916808	0000917092
<b>Board B</b>	0000910199	-----	-----	-----
<b>Board C</b>	0000916889	0000916910	0000916788	0000918002

Note: All rectifiers are UL Listed (UL 1012), UL Recognized (UL 1459) and bear the UL mark for Canada (tested and certified by UL to be in compliance with Canada's CAN/CSA-C22.2 No. 107.9-M91 Standard for Commercial and Industrial Power Supplies).

\*Model equipped with temperature compensated battery charging feature. Designed to protect batteries from overcharging in high temperature conditions.

**International Rectifier Model Specifications (continued).**

<b>Rectifier Module</b>	<b>INTERNATIONAL MODELS</b>		
<b>Model Number</b>	MOD 2420P	MOD 24N20P	MOD 12N20P
<b>Part Number</b>	9144100222	9144100223	9144100218
<b>Input Voltage Range</b>	95 to 264 VAC	95 to 264 VAC	95 to 264 VAC
<b>Input Frequency Range</b>	45 to 65 Hz	45 to 65 Hz	45 to 65 Hz
<b>Output Voltage</b>			
<b>Range</b>	-21 to -28 VDC	+21 to +28 VDC	+9 to +16 VDC
<b>Setting</b>	-26 VDC	+26 VDC	+13 VDC
<b>Output Current</b>			
	20 A (0°C to +40°C) (32°F to 104°F)	20 A (0°C to +40°C) (32°F to 104°F)	20 A (0°C to +40°C) (32°F to 104°F)
	17.5 A (+41°C to +50°C) (106°F to 122°F)	17.5 A (+41°C to +50°C) (106°F to 122°F)	17.5 A (+41°C to +50°C) (106°F to 122°F)
<b>Efficiency, All Input Line Conditions</b> 50% to 100% Load	80%	80%	80%
<b>Power Factor, All Input Line Conditions</b> 50% to 100% Load	0.95	0.95	0.90
<b>Regulation, All Input Line Conditions</b>			
10% to 100% Load	±0.5%	±0.5%	±0.5%
No Load to 100% Load	±0.5%	±0.5%	±0.5%
<b>Input Current</b>			
95 VAC	6.5 A	6.5 A	3.2 A
120 VAC	5.0 A	5.0 A	2.6 A
132 VAC	4.5 A	4.5 A	2.4 A
180 VAC	3.3 A	3.3 A	1.8 A
220 VAC	2.7 A	2.7 A	1.5 A
264 VAC	2.3 A	2.3 A	1.3 A
<b>Output Power</b>	500 Watts	500 Watts	250 Watts
<b>Heat Dissipation</b>			
at 120 VAC	350 BTU/Hr.	350 BTU/Hr.	230 BTU/Hr.
at 220 VAC	310 BTU/Hr.	310 BTU/Hr.	200 BTU/Hr.
<b>For use in Mounting Shelf (Part Number)</b>	7001900016 (UL)	7001900016 (UL)	7001900016 (UL)
<b>Circuit Board Assembly Part Numbers</b>			
Board A	0000916887	0000916887	0000916887
Board B	0000910199	0000910199	0000910199
Board C	0000916912	0000916913	0000916901

Note: All rectifiers are UL Listed (UL 1012), UL Recognized (UL 1459) and bear the UL mark for Canada (tested and certified by UL to be in compliance with Canada's CAN/CSA-C22.2 No. 107.9-M91 Standard for Commercial and Industrial Power Supplies).

### International Extended Temperature Rectifier Model Specifications.

Rectifier Module	INTERNATIONAL EXTENDED TEMPERATURE MODELS				
Model Number	MOD 4810TP	MOD 4810TPC*	MOD 4810TPCA	MOD 4806TP	MOD 4806TPCA
Part Number	9144100217	9144100226	9144100230	9144100221	9144100232
Input Voltage Range	95 to 264 VAC	95 to 264 VAC	95 to 264 VAC	95 to 132 VAC 180 to 264 VAC	95 to 264 VAC 180 to 264 VAC
Input Frequency Range	45 to 65 Hz	45 to 65 Hz	45 to 65 Hz	45 to 65 Hz	45 to 65 Hz
Output Voltage Range Setting	-43 to -56 VDC -52 VDC	-43 to -56 VDC -52 VDC	-43 to -56 VDC -52 VDC	-43 to -56 VDC -52 VDC	-43 to -56 VDC -52 VDC
Output Current	10 A (-40°C to +50°C) (-40°F to 122°F) 7.5 A (+51°C to +65°C) (124°F to 149°F)	10 A (-40°C to +50°C) (-40°F to 122°F) 7.5 A (+51°C to +65°C) (124°F to 149°F)	10 A (-40°C to +50°C) (-40°F to 122°F) 7.5 A (+51°C to +65°C) (124°F to 149°F)	6 A (-40°C to +50°C) (-40°F to 122°F) 5 A (+51°C to +65°C) (124°F to 149°F)	6 A (-40°C to +50°C) (-40°F to 122°F) 5 A (+51°C to +65°C) (124°F to 149°F)
Efficiency, All Input Line Conditions 50% to 100% Load	80%	80%	80%	85%	85%
Power Factor, All Input Line Conditions 50% to 100% Load	0.95	0.95	0.95	0.6	0.6
Regulation, All Input Line Conditions 10% to 100% Load No Load to 100% Load	±0.5% ±1.0%	±0.5% ±1.0%	±0.5% ±1.0%	±0.5% ±0.5%	±0.5% ±0.5%
Input Current					
95 VAC	6.5 A	6.5 A	6.5 A	6.2 A	6.2 A
120 VAC	5.0 A	5.0 A	5.0 A	4.9 A	4.9 A
132 VAC	4.5 A	4.5 A	4.5 A	4.5 A	4.5 A
180 VAC	3.3 A	3.3 A	3.3 A	2.8 A	2.8 A
220 VAC	2.8 A	2.8 A	2.8 A	2.3 A	2.3 A
264 VAC	2.4 A	2.4 A	2.4 A	1.9 A	1.9 A
Output Power	500 Watts	500 Watts	500 Watts	300 Watts	300 Watts
Heat Dissipation					
at 120 VAC	350 BTU/Hr.	350 BTU/Hr.	350 BTU/Hr.	165 BTU/Hr.	165 BTU/Hr.
at 220 VAC	310 BTU/Hr.	310 BTU/Hr.	310 BTU/Hr.	165 BTU/Hr.	165 BTU/Hr.
For use in Mounting Shelf (Part Number)	7001900016 (UL)	7001900016 (UL)	7001900016 (UL)	7001900016 (UL)	7001900016 (UL)
Circuit Board Assembly Part Numbers					
Board A	0000916888	0000916798	0000917091	0000916908	0000917092
Board B	0000916539	0000916539	0000916539	-----	-----
Board C	0000916890	0000916792	0000918001	0000916911	0000917099

Note: All rectifiers are UL Listed (UL 1012), UL Recognized (UL 1459) and bear the UL mark for Canada (tested and certified by UL to be in compliance with Canada's CAN/CSA-C22.2 No. 107.9-M91 Standard for Commercial and Industrial Power Supplies).

\*Model equipped with temperature compensated battery charging feature. Designed to protect batteries from overcharging in high temperature conditions.

**International Extended Temperature Rectifier Model Specifications (continued).**

<b>Rectifier Module</b>	<b>INTERNATIONAL EXTENDED TEMPERATURE MODELS</b>				
<b>Model Number</b>	MOD 2417TP	MOD 24N17TP	MOD 12N17 TP	MOD 12N7.5TP	MOD 24N7.5TP
<b>Part Number</b>	9144100224	9144100225	9144100219	9144100228	9144100229
<b>Input Voltage Range</b>	95 to 264 VAC	95 to 264 VAC	95 to 264 VAC	95 to 132 VAC 180 to 264 VAC	95 to 132 VAC 180 to 264 VAC
<b>Input Frequency Range</b>	45 to 65 Hz	45 to 65 Hz	45 to 65 Hz	45 to 65 Hz	45 to 65 Hz
<b>Output Voltage</b>					
<b>Range</b>	-21 to -28 VDC	+21 to +28 VDC	+9 to +16 VDC	+9 to +16 VDC	+21 to +28 VDC
<b>Setting</b>	-26 VDC	+26 VDC	+13 VDC	+13 VDC	+26 VDC
<b>Output Current</b>	17.5 A (-40°C to +50°C) (-40°F to 122°F) 12.5 A (+51°C to +65°C) (124°F to 149°F)	17.5 A (-40°C to +50°C) (-40°F to 122°F) 12.5 A (+51°C to +65°C) (124°F to 149°F)	17.5 A (-40°C to +50°C) (-40°F to 122°F) 15 A (+51°C to +65°C) (124°F to 149°F)	7.5 A (-40°C to +50°C) (-40°F to 122°F) 7.5 A (+51°C to +65°C) (124°F to 149°F)	7.5 A (-40°C to +50°C) (-40°F to 122°F) 7.5 A (+51°C to +65°C) (124°F to 149°F)
<b>Efficiency, All Input Line Conditions 50% to 100% Load</b>	80%	80%	80%	85%	85%
<b>Power Factor, All Input Line Conditions 50% to 100% Load</b>	0.95	0.95	0.90	0.6	0.6
<b>Regulation, All Input Line Conditions</b>					
<b>10% to 100% Load</b>	±0.5%	±0.5%	±0.5%	±0.5%	±0.5%
<b>No Load to 100% Load</b>	±0.5%	±0.5%	±0.5%	±0.5%	±0.5%
<b>Input Current</b>					
<b>95 VAC</b>	5.6 A	5.6 A	2.9 A	2.1 A	4.2 A
<b>120 VAC</b>	4.4 A	4.4 A	2.2 A	1.6 A	3.2 A
<b>132 VAC</b>	4.0 A	4.0 A	2.1 A	1.5 A	3.0 A
<b>180 VAC</b>	3.0 A	3.0 A	1.6 A	1.1 A	2.1 A
<b>220 VAC</b>	2.5 A	2.5 A	1.3 A	0.9 A	1.8 A
<b>264 VAC</b>	2.1 A	2.1 A	1.2 A	0.8 A	1.6 A
<b>Output Power</b>	500 Watts	500 Watts	200 Watts	100 Watts	200 Watts
<b>Heat Dissipation</b>					
<b>at 120 VAC</b>	350 BTU/Hr.	350 BTU/Hr.	200 BTU/Hr.	60 BTU/Hr.	120 BTU/Hr.
<b>at 220 VAC</b>	310 BTU/Hr.	310 BTU/Hr.	175 BTU/Hr.	60 BTU/Hr.	120 BTU/Hr.
<b>For use in Mounting Shelf (Part Number)</b>	7001900016 (UL)	7001900016 (UL)	7001900016 (UL)	7001900016 (UL)	7001900016 (UL)
<b>Circuit Board Assembly Part Numbers</b>					
<b>Board A</b>	0000916888	0000916888	0000916888	0000916808	0000916808
<b>Board B</b>	0000916539	0000916539	0000916539	-----	-----
<b>Board C</b>	0000916914	0000916915	0000916909	0000916809	0000916812

Note: All rectifiers are UL Listed (UL 1012), UL Recognized (UL 1459) and bear the UL mark for Canada (tested and certified by UL to be in compliance with Canada's CAN/CSA-C22.2 No. 107.9-M91 Standard for Commercial and Industrial Power Supplies).

## RINGING GENERATOR ASSEMBLIES

Each Ringing Generator Module consists of two (2) plug-in circuit boards.

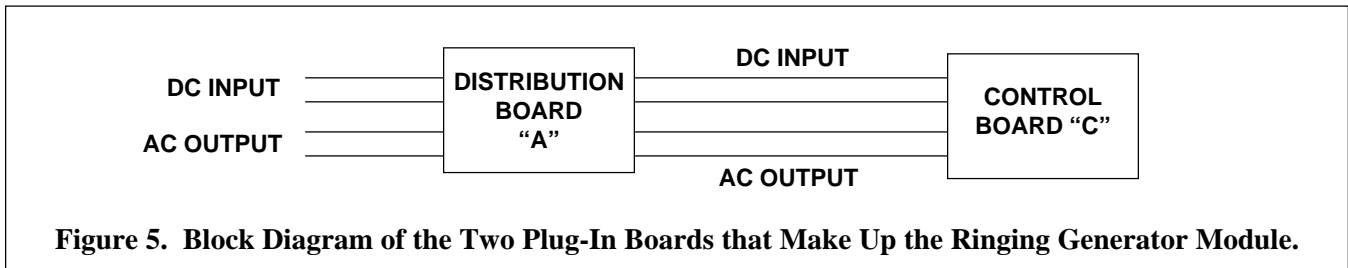

**Figure 5. Block Diagram of the Two Plug-In Boards that Make Up the Ringing Generator Module.**

**“A” Board – Distribution Board** Consists of the Ferroresonant Transformer and AC capacitor, input and output connectors, input circuit breaker, alarm relay, and alarm connector.

**“C” Board – Ringing Generator Control Board** Consists of all the control circuitry which includes crystal oscillator, switching transistors and relays to provide redundant ringer operation.

Note: The “C” Board is identical for the *PS-19* and the *PS-4* external Ringing Generator section; however, the “A” Boards differ.

See Figure 4 for location of the Ringing Generator Boards in the *PS-19* mounting shelf.

### TYPICAL RINGING GENERATOR CHARACTERISTICS.

#### Input Voltage

-42 to -56 VDC.

#### Input Protection

2 Ampere single pole circuit breaker which is accessed from the front with a circuit breaker guard.

#### Low Input Voltage Shutdown

-41 Volts, restart at -47 volts.

#### Output Voltage

90 - 105 Volts AC, 20 Hz.

#### Output Current

200 mA.

#### Output Waveform

See Figure 6

#### Ringing Transfer

Transfer circuit included with each module.

#### Output Fail Alarm

Alarm contacts are provided for each module.

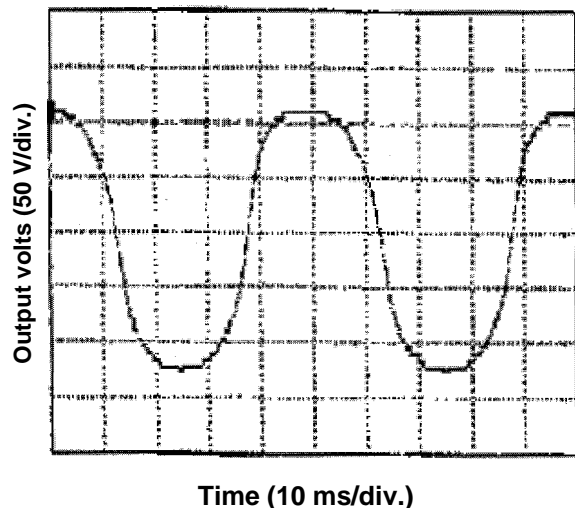

**Figure 6. Output Waveform of 48 Volt, 20 Hz Ringing Generator Module at a 200 mA Load.**

### RINGING GENERATORS AVAILABLE

<b>Model Number</b>	<b>Part Number</b>	<b>Description</b>
MOD RG4820 (UL) Ringing Generator Module	9311600200	-48 VDC Input, 100 VAC, 20 Hz, 20 VA Output, Ringing Generator (0°C to +50°C/32°F to 122°F), UL Listed
MOD RG4815 Ringing Generator Module	9311600202	-48 VDC Input, 100 VAC, 20 Hz, 15 VA Output, Ringing Generator (0°C to +65°C/32°F to 149°F)
MOD RG2420 (UL) Ringing Generator Module	9311500200	-24 VDC Input, 100 VAC, 20 Hz, 20 VA Output, Ringing Generator (0°C to +50°C/32°F to 122°F), UL Listed

### *PS-4 Options for PS-19 TwinPack® Power Systems*

#### **PS-4 Configurations (ordering information).**

<b>Model Number</b>	<b>Part Number</b>	<b>Description</b>
PS-19/PS4-ERG (UL)	7001900013	<i>PS-19</i> Mounting Shelf with <i>PS-4</i> optional shelf for mounting external ringing generator (MOD ERG4820) - UL 1012 Listed.
PS-19/PS4-8F	7001900015	Mounting Shelf identical to 7001900010 with PS-4 section added with 8 each GMT fuse positions. Bears the UL mark for Canada.
PS-19H/PS4-48 LVD	7001900029	Mounting Shelf identical to 7001900016 with PS-4 section with -48 LVD added.
PS-19/PS-4L with Rear GMT (UR)	7001900034	Mounting shelf identical to 7001900010 with PS-4 section with -48 LVD and 16 GMT fuses (rear) added.
	7001900014	Heat Deflector - 3.5" (9 cm) (2 RU) high x 23" (58 cm) wide (for all <i>PS-19/PS-4</i> configurations).



**7001900013 Mounting Shelf**

**Optional Accessories for PS-19 Mounting Shelves  
(add 1.5" (3.8 cm) to overall depth of shelf).**

<b>Part Number</b>	<b>Description</b>	<b>Weight (Lbs./Kgs.)</b>
7001900030	8 Position GMT Rear Fuse Panel	2.5/1
7001900031	16 Position GMT Rear Fuse Panel	3.0/1.4

GMT Type Fuses are ordered separately by the part numbers listed below.

<b>Type</b>	<b>Amps</b>	<b>Part Number</b>	<b>Type</b>	<b>Amps</b>	<b>Part Number</b>
GMT	1.0	1125230010	GMT	3.0	1125230030
GMT	1.33	1125230013	GMT	5.0	1125230050
GMT	2.0	1125230020			